

**Author:** dr inż. Joanna Szkudlarek, Iga Drobina

**University:** Centralny Instytut Ochrony Pracy-Państwowy Instytut Badawczy,  
Uniwersytet Śląski w Katowicach Wydział Prawa i Administracji

**Poster title:** A NEW TEST STAND FOR THE SWITCHING TIME OF AUTOMATIC WELDING FILTERS EVALUATION - NEW POSSIBILITIES FOR ASSESSING THEIR PROTECTIVE PARAMETERS

The work aim is to provide information on a new possibilities for assessing the protective properties of automatic (auto-darkening) welding filters (AWFs) in terms of switching time. The presentation of the new test stand is particularly important for AWF manufacturers and engineers designing new constructions of welding shields equipped with AWFs. The new test stand opens the possibility of testing panoramic welding filters and AWFs integrated with welding shield bodies.

#### Introduction

Automatic welding filters (AWFs) are designed to make welding safer. Welding is classified as a hazardous occupation due to the simultaneous occurrence of various risks, including mechanical, thermal, optical, and exposure to toxic vapors and fumes. Automatic welding filters (so-called active), unlike passive filters, automatically switch from a light to a darkened state as a result of an optical impulse. They provide effective protection for welders' eyes against exposure to harmful optical radiation, especially during accidental ignition of the welding arc or when near other welders' arcs. The filter's protective properties include attenuation of the luminance of the welding arc to a safe level (protection against intense visible radiation that can cause glare) and protection against harmful UV and IR radiation (which are invisible to humans).

The automatic welding filter consists of a structure composed of a liquid crystal screen (comprising layers of polarizers), solar cells, a housing made of plastic, an electronic module, detectors detecting the welding arc and protective glass. In short, the phenomenon causing the effect of darkening and brightening the filter occurs due to liquid crystals located between polarizing filters, which change polarization under the influence of applied voltage (rotate the polarization of light by 90 degrees) [1, 2].

The construction of welding protectors equipped with AWFs and AWF units themselves has evolved over several decades. In the past, welding shields, primarily involved welding helmets with replaceable AWFs. However, modern developments have led to integrated structures that combine AWF technology with welding protection bodies, such as AWFs integrated with goggles (as shown in Figure) [3].



Figure 1. New constructions of welding shields with automatic welding filter: a) welding shields with curved AWF; b) auto-darkening welding goggles with AWF and face shield integrated [4,5].

#### Utilitarian and scientific justification for this work

The introduction of new designs of welding filters and welding shields integrated with AWF to the market has several significant consequences :

1. Standardization efforts to implement changes in requirements and testing methodologies,
2. The need to adapt laboratory equipment to accommodate these new requirements and research methodologies.

A newly constructed test stand in the CIOP-PIB laboratory has been specifically designed to meet the requirements outlined in the new ISO standards and to facilitate the testing of a wide range of welding shields equipped with AWFs.

A universal test stand for assessing switching time has been developed following the specifications detailed in the new standards including PN-EN ISO 18526-1:2020-09 [6], PN-EN ISO 16321-2:2022-03 [7] and the standards referred to.

Figure 2 illustrates the concept of a test stand for evaluating switching time following these standards.

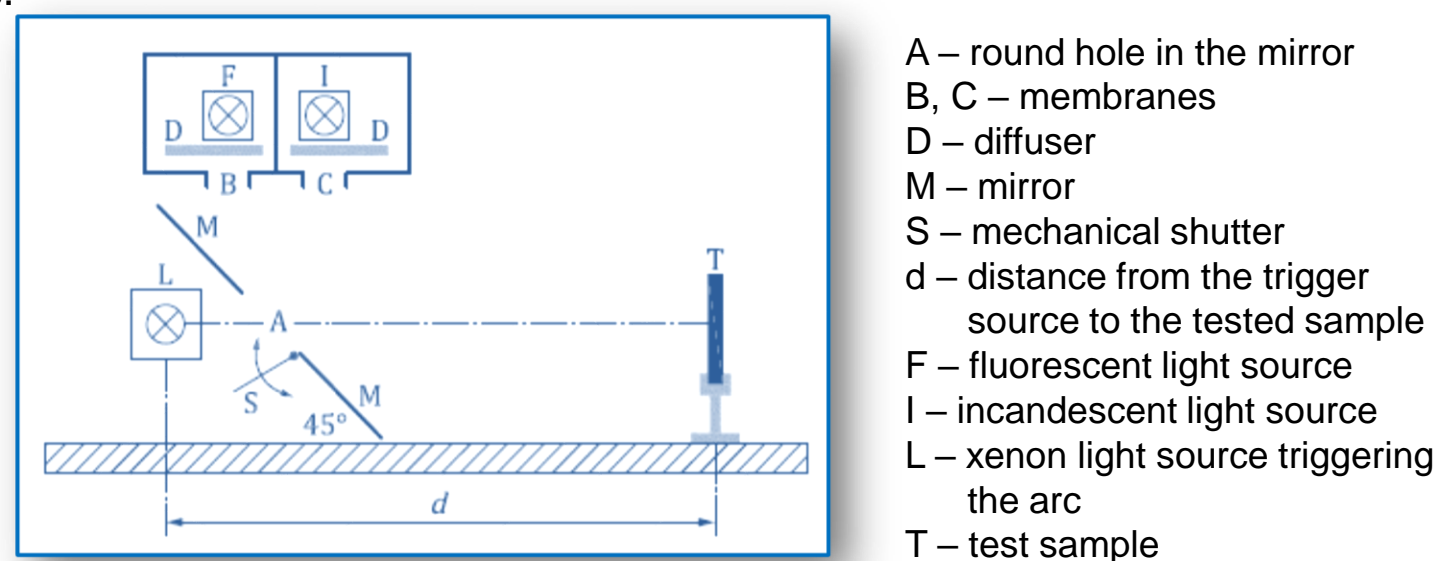

Figure 2. Concept of a test stand for evaluating switching time in accordance with the standards [6, 7].

Figure 3. shows the concept of the filter illuminating during the tests.

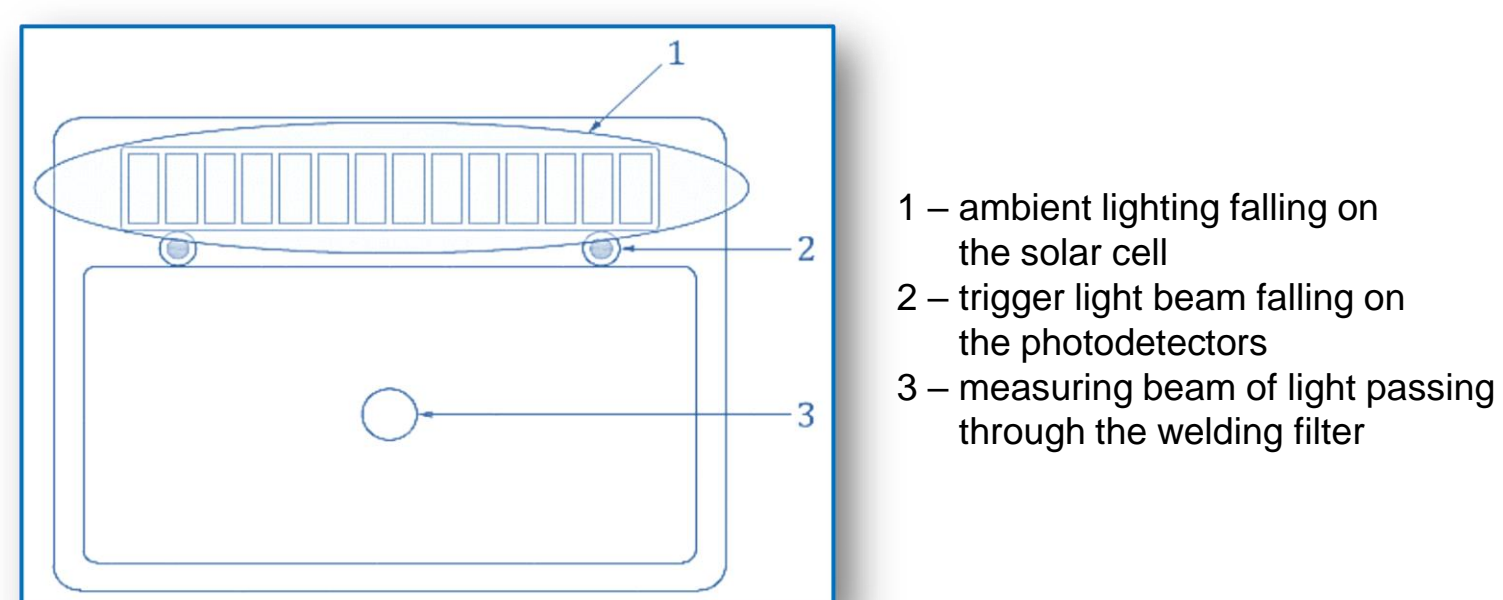

Figure 3. Concept of illuminating the sample during testing in accordance with Annex E of the PN-EN ISO 18526-2:2020-09.

The test stand consists of an illumination system (a) and two optical detectors placed inside the human head model (b), representing the location of the eyeballs. The level of darkening will be calculated as the quotient of the amount of light passing through the filter in the dark state to the amount of light passing through the filter in the bright state. Two diodes (a) placed on the measurement axis (f) will serve as the measurement light source, illuminating the two detectors (b). This configuration ensures a close approximation to natural lighting conditions during welding, achieved through a point light source and the aforementioned placement of detectors. The trigger light source (c) will also be a diode within the visible (VIS) range, with appropriately adjusted brightness, directed straight onto the detector, ensuring effective separation of trigger light from measured light.

The critical aspect lies in controlling the sample positioning during measurement. The new standard imposes strict accuracy requirements regarding the angle of the measuring light beam in relation to the filter. Specifically, the new standard demands an angle with a value and precision of  $(90 \pm 1)^\circ$ , whereas the previous standard allowed for an accuracy of  $(90 \pm 5)^\circ$ . Consequently, a specialized system has been developed to maintain the correct filter orientation.

The filter's perpendicularity to the optical axis will be ensured through a manually operated mechanical system (d). The measurement of the filter switching time will be calculated by the microcontroller following the integral formula described in Annex C, point C.3.7 of the PN-EN ISO 18526-2:2020-09. The device will be equipped with two temperature sensors and temperature control will be maintained at the required level using a thermostatic heating and cooling system (e), as depicted in the side view. The new test stand for evaluating the switching times of automating welding filters (AWFs) is presented in Figure 4.

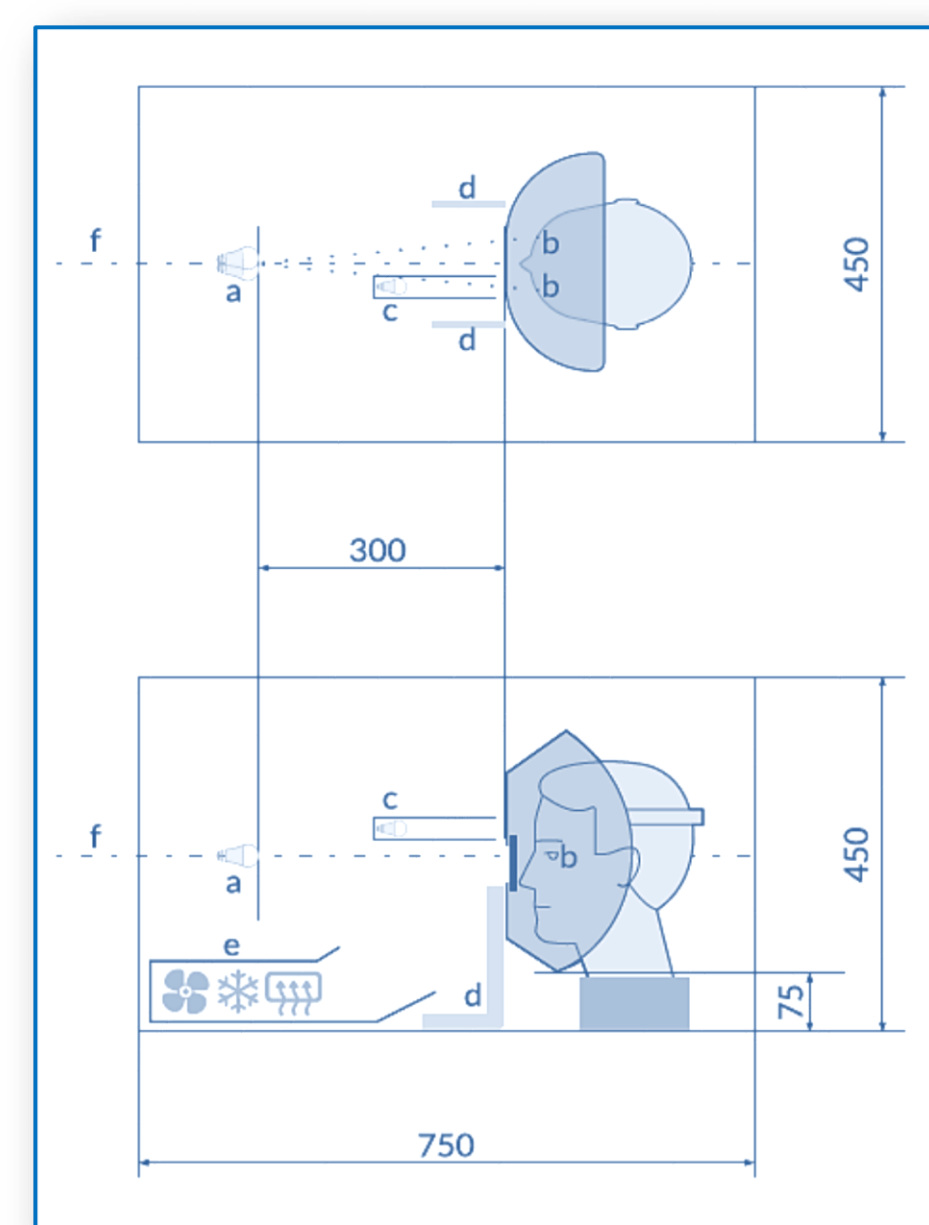

Figure 4. View of the test stand for switching time evaluation.

The new test stand for evaluating the switching time of AWFs must meet the requirements of the new ISO standards and must possess sufficient versatility to accommodate emerging trends in welding protection structure design. The key considerations for the construction of this new testing stand for switching time assessment are outlined below:

1. Ensures the required blackout conditions (in connection with determining transmission coefficients as data necessary to determine the switching time),
2. Dimensions - correlated with the maximum dimensions of welding protection bodies to ensure comfortable installation and positioning of samples,
3. Temperature stability - requirements for the construction elements of the stand,
4. Universal sample mounting system - enabling testing of various types of welding protection (head model that will ensure natural conditions for the use of protection) and it should incorporate a light angle control system to ensure the required accuracy,
5. Measurement system - based on dedicated computer software - full automation of data collection and processing and displaying the final result on an LCD touch screen,
6. Trigger system - allows to switch the filter from light to dark state, while being separated from other light sources,
7. Lighting system - system that meets the standard's requirements, consists a specialised electronic system capable of rapid turn on/off,
8. Detection module - mapping real conditions during welding (with detectors positioned at eye level, on lines of sight),
9. Microprocessor control module - ensuring control and synchronization of all active modules and performing measurements,
10. Heating and cooling module - ensuring the required conditions for measurements as defined in the standard, enabling the required temperature stability in the time (one hour before the testing).

#### Conclusion

The work aimed to introduce a new test stand for the precise determination of the switching time of automatic welding filters (AWFs).

New trends in the design of welding shields equipped with AWFs, which respond to the needs of users, bring a consequence in standardization work. As innovative technical solutions in Personal Protective Equipment (PPE) emerge, it becomes imperative to establish new standards and research methodologies tailored to these advancements.

In response to the innovative developments in welding shield constructions equipped with AWFs and the accompanying normative changes, research laboratories must adapt their measurement equipment and construct modern test stands to meet these evolving needs.

The development of a new test stand for assessing the switching time of AWF is currently underway at CIOP-PIB, with collaborative efforts between CIOP-PIB and the nProLab company, spanning the years 2023-2024.

The CIOP-PIB Eye and Face Protection Laboratory invites entrepreneurs - manufacturers of AWFs and welding shields equipped with AWF to cooperate in the field of testing, testing of prototypes, and innovative constructions integrated with AWFs.

#### Literature

1. OWCZAREK G., GRALEWICZ G., Metody indukowania zmian przepuszczania promieniowania widzialnego dla optycznych filtrów ochronnych blokujących szkodliwe promieniowanie podczerwone, Zeszyty Naukowe Wyższej Szkoły Zarządzania Ochroną Pracy w Katowicach, Nr 1(12)/2016, s. 89-102, ISSN-1895-3794
2. POŚCIK A., KUBRAK J., WŁODARSKI L.: Barwniki fotochromowe, interferencja światła i automatyczne filtry spawalnicze, Prace Instytutu Elektrotechniki, zeszyt 228, 2007, s. 155-166
3. Materiały informacyjne firmy Delta technika, Katalog Produktów 2016-2017; <https://www.deltatechnika.pl/wp-content/uploads/2016/01/Katalog-spawalnictwo.pdf>, 17.10.2023.
4. Grafika: <https://sklep.rywal.com.pl/img/159592/-przy%C5%82bica-spawalnica-3m%E2%84%A2-speedglas%E2%84%A2-g5-02-rywal-rhc-sklep-internetowy.jpg> - 02.11.2023
5. Grafika: <https://icd.pl/media/catalog/product/cache/33055300548d0f7a1ad149a0bbcf7b38/g/o/go-ple-spawalnica-servore-arc-shield-2-visor-hb.jpg> - 02.11.2023
6. Polski Komitet Normalizacyjny, PN-EN ISO 18526-2:2020-09. Ochrona oczu i twarzy – Metody badań. Część 2: Fizyczne właściwości optyczne.
7. Polski Komitet Normalizacyjny, PN-EN ISO 16321-2:2022-03. Ochrona oczu i twarzy do zastosowań zawodowych. Część 2: Dodatkowe wymagania dla środków ochrony stosowanych podczas spawania i technik pokrewnych.

This paper is published and based on the results of a research task carried out within the scope of the sixth stage of the National Programme "Governmental Programme for Improvement of Safety and Working Conditions" supported within the scope of state services by the Ministry of Family and Social Policy. task no. 1.ZS.05, entitled "Development of a method for testing the switching time of automatic welding filters". The Central Institute for Labour Protection – National Research Institute is the Programme's main co-ordinator.